

WATSN Automatic Transfer Switch

Catalogue 2021



FENIGAL ELECTRIC
Operated by
WUXI FENIGAL SCIENCE AND TECHNOLOGY CO., LTD.



About Schneider Electric

As an expert service provider in the global energy management and automation, Schneider Electric is leading the digital transformation for efficiency and sustainability. With over 135,000 employees in more than 100 countries, our sales hit 27.2 billion Euros in FY 2019.

In Schneider Electric, We believe **access to energy and digital** is a basic human right. We empower **all to make the most of our energy and resources**, ensuring **Life Is On** everywhere, for everyone, at every moment.

We provide **energy and automation digital solutions** for **efficiency and sustainability**. We combine world-leading energy technologies, real-time automation, software and services into integrated solutions for homes, buildings, data centers, infrastructure and industries.

We are committed to unleash the infinite possibilities of an **open, global, innovative** community that is passionate about our **Meaningful Purpose, Inclusive and Empowered** values.

WATSN Automatic Transfer Switch Table of Contents



WATSN Series Class PC

- Excellent performance 2
- General features 4
- Ordering Information..... 5
- Functions and characteristics 6
- Controller function overview 8
- Type A controller 9
- Remote Transfer Switching Equipment 11
- Mechanical and electrical Accessories 12
- Dimensions and connections 13
- Electrical wiring..... 16
- Commercial References 17

Automatic Transfer Switch



Class PC >

- Transfer switch equipment based on mechanical switching devices, that do not need electrical power to hold the main contacts open or closed and capable of making, carrying, and breaking currents under normal circuit conditions including operating overload conditions, and making and withstanding short-circuit currents.

Extract from IEC60947-6-1

WATSN automatic transfer switch is specially designed in accordance with the standard requirements for power transfer. It does not provide protection but has a great withstanding and connectivity capacity. In other words, it can guarantee the safety of switch itself, and will not be damaged due to failure such as overload or short circuit, thus keeping a reliable connectivity of circuits.

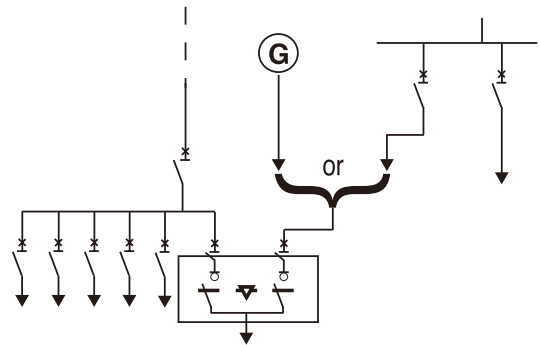



**Green
Premium™**
Product

WATSN series Class PC Automatic Transfer Switch >

- Compact, artful, outstanding, high-class, comprehensive, inclusive, flexible, customized
- Energy efficient, stable, and safe
- Fully equipped with the TIDE 2.0 intelligent control system

Class PC transfer switch

Excellent performance



Compact

Reduced size and footprint

- The product size is fully optimized and upgraded, which is more compact than equivalent products
- The width of a power distribution cabinet can be as small as 400 mm to minimize space, resources, and costs
- The controller has a new architecture and compact design, saving up to 30% for overall dimensions and floor space



Artful

Gathering of unique craft and ingenuity

- Solenoid drive and integrated ATS with three positions realizes fast transfer in 100 ms
- Electromagnet comes with overheating self-protection mechanism and easily copes with severe temperature challenges
- With an exquisite handle structure, manual/automatic interlock design, and standard off isolation padlock, it realizes safe and reliable maintenance
- Core switch components support self-inspection and active operation and maintenance avoids off time



Outstanding

Excellent performance comes from lots of tests and practices

- Category AC-33B meaning ATSE can make or break current 10 times higher than nominal current.
- Meet the requirements for switchgear category E/F according to IEC 60947-6-1; the EMC level is E2, and it can withstand a harsh environment
- The controller uses a 32-bit intelligent processor, which greatly improves the computing power and real-time sampling performance
- Over-current protection coordination with upstream protection (circuit-breaker as example)



High-class

Quality-oriented, safety first

- Powerful and automated lean production lines achieve energy efficient, which is safe and stable
- The incoming quality control (IQC) process includes automatic compression and high-class products come from intelligent manufacturing
- Final quality control (FQC) process provides an improved capability of quality inspection and control, where craftsmanship spirit ensures consistent high quality

Excellent performance



Comprehensive

Wisdom comes from a collection of cutting-edge technologies while intelligence leads to a great success

- All types of controllers support the Modbus communication protocol and a connected IoT era starts from now



Inclusive

Easy to meet different needs

- Simple and comprehensive control types: automatic, manual, remote control, to meet various control needs
- Compliant with CB & CE certifications and RoHS & REACH requirements, as well as international standards, which is environmental friendly and efficient
- The DIN rail or base plate installation methods
- The integrated Type A controller featuring a design, supporting installation of cabinet doors, with operating status clear at a glance



Flexible

Scalable features that support both assembly and expansion

- Flexible support for function expansion, customized on demand, and easy to extend
- Add-on modules have a unified appearance and the standardization is only to make changes easier
- Modules are ordered separately, easy to plug and play on site, functional in real time, and easily respond to new needs



Customized

Care and implement everything that you need

- Fully equipped with the TIDE 2.0 intelligent control system and the architecture design is unified for all control systems
- All power failure, switch failure status, event log, query and analysis are clear at a glance
- T-Helper, an operation and maintenance assistant, is an added feature and enables a new operation and maintenance experience

Class PC transfer switch

General features



Codes and standard

- | | |
|-----------------|------------------------------|
| • IEC 60947-1 | General rules |
| • IEC 60947-6-1 | Transfer switching equipment |
| • GB 14048.1 | General rules |
| • GB/T 14048.11 | Transfer switching equipment |

Codes and certifications and declarations

- CCC certification
- CE certification
- CB certification
- RoHS 2.0 certification
- REACH declarations

Operating conditions

- WATSN series Class PC transfer switch can operate in an ambient temperature of $-25^{\circ}\text{C} \sim +70^{\circ}\text{C}$
- The altitude of the installation site shall not exceed 2000 m
- When the highest temperature is $+55^{\circ}\text{C}$, the relative humidity in air shall not exceed 95%
- Storage temperature: $-35^{\circ}\text{C} \sim +85^{\circ}\text{C}$

Electromagnetic compatibility (EMC)

WATSN series Class PC automatic transfer switch can withstand:

- | | |
|--|---------|
| • Electrostatic discharge | Level 3 |
| • Radiation immunity in a RF electromagnetic field | Level 3 |
| • Electrical fast transient burst | Level 3 |
| • Power surge | Level 3 |
| • Conducted immunity in a RF electromagnetic field | Level 3 |
| • Radiation level | Level B |

Pollution degree

WATSN series Class PC transfer switch can operate in an environment with the pollution degree 3

Switch Class

Based on the definitions specified in the transfer switch standard, WATSN includes the Class PC

Utilization category

AC-33B

Ordering Information

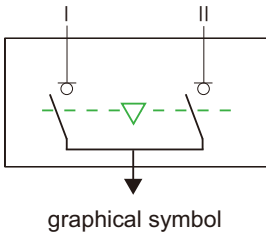

Catalogue Number

WATSN	63	/	4	A	V
Schneider Wingoal	Rated operating current		Number of poles	Control types	Additional feature
WATSN series transfer switch			2	A	V - over-voltage and under-voltage
			3	R	
			4		

- Notes:**
1. Rated operating current (A): 63,160b, 250, 630
 2. Number of poles: 2-2 poles (up to 250 A), 3-3 poles, 4-4 poles
 3. Control types: Type A - basic controller (16-630 A), Type R - remote control
 4. Additional option: V - over-voltage and under-voltage, which can implement the transfer function between over-voltage and under-voltage and can adjust the transfer threshold through a specialized device. It's only optional for Type A controller

> Add-on module

X - Fire linkage module

- 5 fire signaling modules available and one of them can be chosen: X1 - DC24V constant voltage fire module; X2 - DC24V pulse fire module; X3 - AC220V constant voltage fire module; X4 - AC220V pulse fire module; X5 - passive fire module

G - Generator starting/cool down module

- Provide normally closed/open contacts. After the main power supply fails, the contact status changes to start the generator, and the generator is closed after the main power supply restores
- Passive switch signals output, the terminal capacity is DC30V 2A

T - Communication module

- It is equipped with a RS485 interface and supports the Modbus communication protocol
- It can be connected to the on-site operation and maintenance assistant T-Helper, which provides more on-site setting options
- Applicable to power monitoring system, it can implement signaling, measurement, and adjustment remotely with the monitoring host

GT - Generator starting/cool down + Communication module

- It supports generator starting/cool down and communication functions at the same time and the generator starting terminal supports a capacity of DC30V 2A

RC2 - Remote transfer-to-standby module

- Provide passive input terminals that can remotely control the switch and transfer it to the closed position of standby power supply

> F - Auxiliary contact OF-contact module (optional for 100/160 frame)

- It provides normally closed/open contacts. When the switch is in different positions, it provides passive switch signal output indications
- The product with 100/160 frame provides optional F position feedback module and the product with 250/630 frame equipped with position feedback function by default

Notes:

1. The add-on functions and modules on an Type A controller can be combined at random, but only select the same function once for a controller.
2. On an Type A controller, the number of combined add-on modules X, G, T, GT, RC2 shall not exceed two at the same time

Class PC transfer switch

Functions and characteristics



Frame		
Rated operating current (A)	le	AC-33B
Number of poles		
Operating positions		
Control types		
Electrical features determined by GB/T 14048.11 (IEC 60947-6-1)		
Rated insulation voltage (V)	Ui	
Rated impulse withstand voltage (V)	Uimp	
Rated operating voltage (V)	Ue	AC50/60Hz
Rated operating frequency (Hz)	f	
Rated short-time withstand current (kA/60ms)	Icw	
Rated short-circuit making capacity (kA)	Icm	
Peak Current (kA)	Ipeak	
Mechanical durability		
Electrical durability		
Installation and connection		
Installation method		
Wiring method		
Auxiliary device		
Off padlock		
Position feedback		
Terminal cover		
Rail buckle		
Terminal insulation cover		
Interphase insulating screen		

Notes: ■ Standard □ Optional
(1) default 230V/400V

Functions and characteristics

	100	160	250	630
	63	160	250	630
	2, 3, 4	2, 3, 4	2, 3, 4	3, 4
	3	3	3	3
	A, R	A, R	A, R	A, R
	690	800	800	800
	6000	8000	8000	8000
	2P: 220-240V/3P, 4P: 380-415V	2P: 220-240V/3P, 4P: 380-415V	2P: 220-240V/3P, 4P: 380-415V	380-415V ⁽¹⁾
	50/60	50/60	50/60	50/60
	5	10	10	12.6
	7.65	17	17.24	25.55
	16.24	20.84	20.04	33.91
	8000	10000	10000	10000
	6000	6000	6000	6000
	Rail/base plate	Rail/base plate	Base plate	Base plate
	Cable	Flat-facing bars	Flat-facing bars	Flat-facing bars
	■	■	■	■
	□	□	■	■
	□	□	-	-
	□	□	-	-
	■	■	-	-
	-	-	□	□

Class PC transfer switch

Controller function



Type A controller

Controller Type	Type A
Installation method	Integrated
Automatic transfer	
No voltage or loss of phase for power supply I	■
No voltage or loss of phase for power supply II	■
Power supply I under-voltage	■
Power supply II under-voltage	■
Power supply I over-voltage	■
Power supply II over-voltage	■
Self-return	■
Non-return	■
Manual return	■
Control operation	
Remote control transfers to power supply I	-
Remote control transfers to power supply II	□ ⁽²⁾
Remote control transfers to OFF position	-
Fire signal transfers to OFF position	□ ⁽²⁾
Transfer function test	■
Signal output	
Generator starting/cool down signal	□ ⁽²⁾
Display	
Power status	LED
Switch/contact status	LED
Event log	□ ⁽¹⁾
Setting	
Transfer delay	■
Retransfer delay	■
Transient delay	□ ⁽¹⁾
Under-voltage threshold setting	□ ⁽¹⁾
Over-voltage threshold setting	□ ⁽¹⁾
Communication parameter settings	□ ⁽¹⁾
Fire linkage function	
DC24V constant voltage	□ ⁽²⁾
DC24V pulse	□ ⁽²⁾
AC220V constant voltage	□ ⁽²⁾
AC220V pulse	□ ⁽²⁾
Passive fire signal	□ ⁽²⁾
Other functions	
Communication function	□ ⁽²⁾

Notes: ■ Standard configuration □ Optional configuration or service

(1) Adjust the settings by using T-Helper, the O&M assistant. If necessary, please consult our company and complete the settings under the guidance of professional technicians or the support of specialized devices

(2) Implement it by the function expansion module

Type A controller

> Parameter

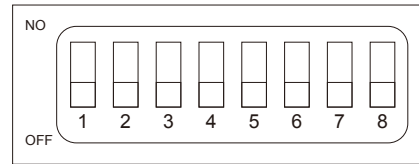

Operating mode setting			Transfer delay setting				Return delay setting			
1	2	Operating mode	3	4	5	Delayed time (s)	6	7	8	Delayed time (s)
OFF	OFF	Self-return	OFF	OFF	OFF	0	OFF	OFF	OFF	0
OFF	ON	Non-return	OFF	OFF	ON	5	OFF	OFF	ON	5
ON	ON	Manual-return	OFF	ON	ON	15	OFF	ON	ON	15
			ON	ON	ON	30	ON	ON	ON	30

> Test function

- After the product is powered on, you can use the test function to detect whether the product can be transferred normally. When performing test function, it is necessary to place the switch in the automatic operating mode and transfer the power supply I to the closed position under the premise that the power supply is normal.
 - When you press the Test keypad under the premise that the powersupply II is normal, the switch will complete an I-O-II-O-I operation cycle.
 - When you press the Test keypad in case that the power supply II is abnormal,the controller will send a generator starting signal (if equipped with aGenerator starting/closing module). If the power supply II restores to normal within 60s, the switch will complete an I-O-II-O-I operation cycle. If the power supply II fails to restore to normal within 60s, the switch will not perform any transfer action and controller quit function test process.
- When the product fails and an audible and visual alarm is triggered, press theTest keypad for muting.

> Reset function

- Reset keypad: The controller will reset and repeat the process when you press the Reset keypad. After trouble shooting, press the Reset keypad to start a new round of signal detection and judgment.

> Indicator status



Indicators	Status	Meaning
Power supply I status indicator	On	Power supply I is normal
	Blinking	Power supply I fails
	Off	Power supply I is not powered on
Power supply II status indicator	On	Power supply II is normal
	Blinking	Power supply II fails
	Off	Power supply II is not powered on
Power supply I closure indicator	On	Power supply I closed
	Off	Power supply I open
Power supply II closure indicator	On	Power supply II closed
	Off	Power supply II open
Alarm indicator	Blinking	Failure alarm status
	Off	Normal operating status
Run indicator	On	Normal automatic operating status
	Off	Normal manual operating status

Class PC transfer switch

Type A controller



An add-on module

> Add-on

① X - Fire modules		② T - Communication module	
X1	DC24V constant voltage fire module	③ G - Generator starting/cool down module	
X2	DC24V pulse fire module		
X3	AC220V constant voltage fire module	④ GT - Generator starting/cool down + communication module	
X4	AC220V pulse fire module		
X5	Passive fire module	⑤ RC2 - Remote transfer-to-standby module	

- The Type A controller can be equipped with a variety of add-on function modules that can be combined flexibly and support plugging and playing on site
- When the Type A controller expands its functions, different functions can be combined at random and you can only select the same function once for a controller. The number of any combined modules cannot exceed two

Over-voltage and under-voltage function

- When you select a product with the function to monitor and detect over-voltage and under-voltage, you can adjust the over-voltage and under-voltage thresholds to transfer based on your site requirements. For the range of over-voltage and under-voltage thresholds, see the table below

Parameter	Number of poles	Adjustable range	Factory default	Unit
S1 under-voltage threshold	2P、4P Phase-Neutral	160-190	180	V
	3P Phase -Phase	280-360	310	V
S2 under-voltage threshold	2P、4P Phase-Neutral	160-190	180	V
	3P Phase -Phase	280-360	310	V
S1 over-voltage threshold	2P、4P Phase-Neutral	240-280	260	V
	3P Phase -Phase	420-480	460	V
S2 over-voltage threshold	2P、4P Phase-Neutral	240-280	260	V
	3P Phase -Phase	420-480	460	V

> T-Helper

- T-Helper is an operation and maintenance assistant that can be connected to the Type A controller through the communication module T. It can implement more adjustable options on site and read more operating information, which facilitates operation and maintenance in the future
- If you want to implement more functions such as configuration or read by using T-Helper, please consult our company and complete the settings under the guidance of professional technicians and the support of specialized devices



T-Helper

T-Helper function overview

Operation	Function	Parameter
Setting	Communication parameters	Address
		Baud rate
		Check bit
		Stop bit
	Threshold setting	S1 under-voltage
		S1 over-voltage
		S2 over-voltage
Delay setting	Transient delay	
Voltage calibration	230V/400V	
Factory setting	Restore to factory setting	
Read	Status information	Switch status
		Power status
		Running status
		Number of transfers
	Product information	Manufacturing No.

Remote Transfer Switching Equipment



Frame 100A



Frame 250A

No display or controller, simply transfer switch with a remote transfer function module.

> Overview:

What is a Remote Transfer Switching Equipment (RTSE)?
According to IEC 60947-6-1, RTSE is remotely operated transfer switching equipment. It is the most commonly used system for transfer loads without direct human intervention. Transfer process is conducted electrically.

in some occasions, customers want to use a third-party system to control the TSE from distance (such as control room), or users want to use an intelligent system to operate the TSE, which requires remote control functions.

WATSN provides RTSE by utilizing a transfer switch and a standard remote transfer function module which is installed on type R controller.
To trigger transfer, an Impulse signal larger than 100ms is needed. No need of driving power from Main Circuit or other external power.
Utilizing the function module, TSE can be remote to either normal position, alternate position or OFF position.

> Electrical Wiring

Wiring diagrams of function expansion modules for WATSN RTSE

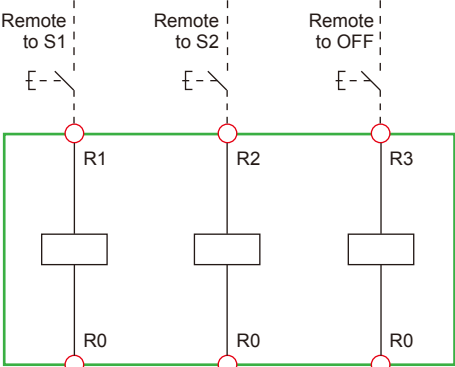

RTSE Remote control signal input time should be $\leq 100\text{ms}$

Notes: only one of R1, R2, R3 can be connected to R0 at the same time.

Remote control terminal:

Terminal function: External control input terminal
Terminal signal type: passive input terminal
R0, R1 terminal closed, switch remote to SI.
R0, R2 terminal closed, switch remote to SII.
R0, R3 terminal closed, switch remote to OFF position.

Impulse Logic

		$\geq 100\text{ms}$		$\geq 100\text{ms}$			
Command I							
Command O							
Command II							
Position I							
Position O							
Position II							

Class PC transfer switch

Mechanical and electrical accessories



OF-contact module

OF-contact module

- Provide the open and closed status indication for switches on both source I and source II. It can be ordered separately, flexibly plugged and unplugged, and function immediately
- Each group of contacts can indicate the status of switches on both side respectively; the product with 100/160 frame is optional (up to 2 sets), and the 250/630/1250 frame product is standard (1 set)



Terminal Shield

Terminal Shield

- Provide terminal protection on the cable incoming and output, making the wiring safer
- This accessory is optional for 100/160 frame product



Rail buckle

Rail buckle

- It can be used to snap in and fix your product between the DIN 35 mm guide rails when the guide rail is used for installation
- This accessory is optional for 100/160 frame product



interphase barrier

Interphase barrier

- Provide protection for the cable incoming and output, effectively avoiding short circuits between phases
- This accessory is optional for 100/160 frame product

Circuit-breaker / Transfer Switch Equipment coordination

Complementary
technical informations
Ue <=415 VAC

Upstream
Downstream

EasyPacT CVS
WATSN

Load side :		TSE	WATSN			
		Rating	100	160	250	630
		Ith (A) 40°C	100	160	250	630
		Icw (kA)	5	10	10	12
		Icm (kAp)	7.65	17	17	25
Supply side	Icu (kA)					
Circuit breaker:	415V	Ir	TSE conditionnal short-circuit current and related making capacity:			
CVS100B	25		5	T	T	T
CVS160B	25			T	T	T
CVS250B	25				T	T
CVS100F	36		5	25	25	T
CVS160F	36			25	25	T
CVS250F	36				25	T
CVS400F	36					36
CVS630F	36					36
CVS100N	50		5	25	25	T
CVS160N	50			25	25	T
CVS250N	50				25	T
CVS400N/H	50/70					36
CVS630N/H	50/70					36

- T Transfer Switch Equipment is Totally coordinated up to Icu of circuit breaker installed on supply side.
- Protection of the Transfer Switch Equipment is not ensured

Class PC transfer switch

Dimensions and connections

Outline and installation dimensions (mm) for WATSN 100/160⁽¹⁾ frame

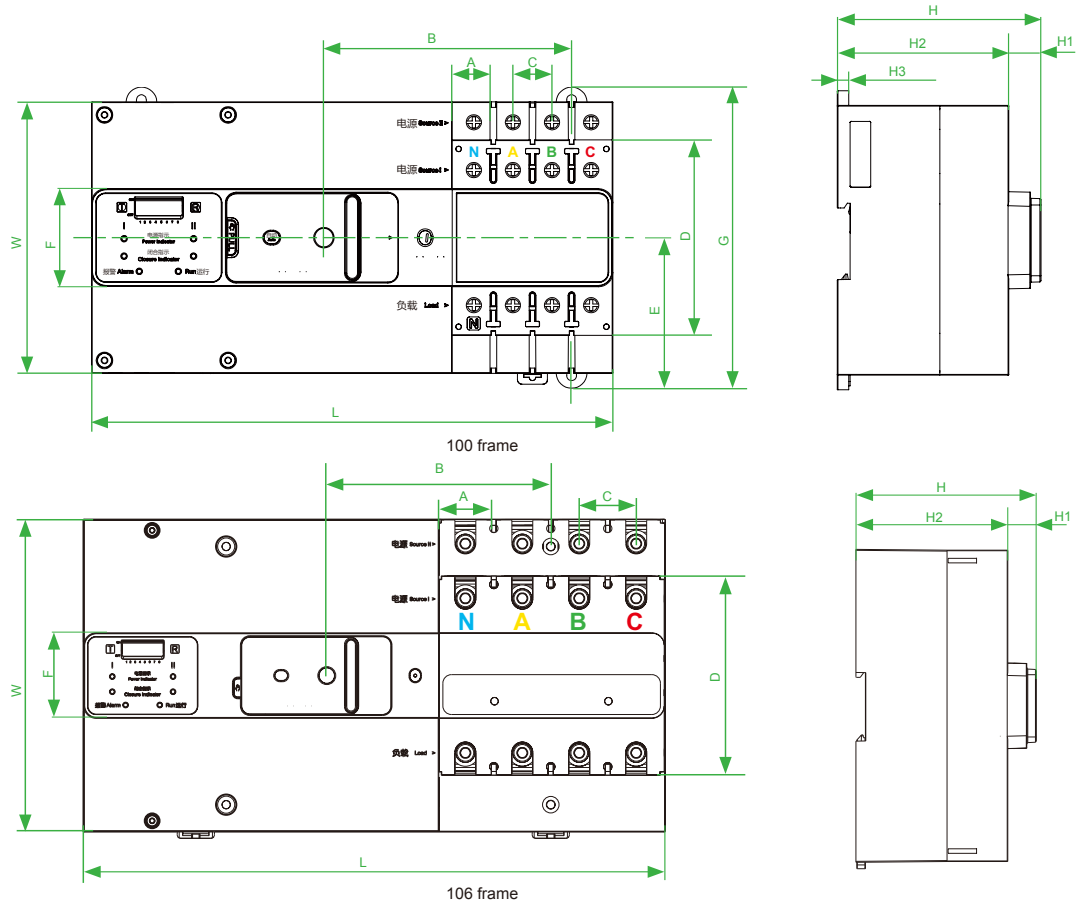

Dimension Frame	Outline dimensions			Other dimensions									
	L	W	H	A	B	C	D	E	F	G	H1	H2	H3
100-2P	240	125	94.5	15	114	18	90	63.5	45	138.6	15	79.5	5.4
100-3P	240	125	94.5	15	114	18	90	63.5	45	138.6	15	79.5	5.4
100-4P	240	125	94.5	15	114	18	90	63.5	45	138.6	15	79.5	5.4
160-2P	306	164	95	28	118	30	105	-	45	-	15	80	-
160-3P	306	164	95	28	118	30	105	-	45	-	15	80	-
160-4P	306	164	95	28	118	30	105	-	45	-	15	80	-

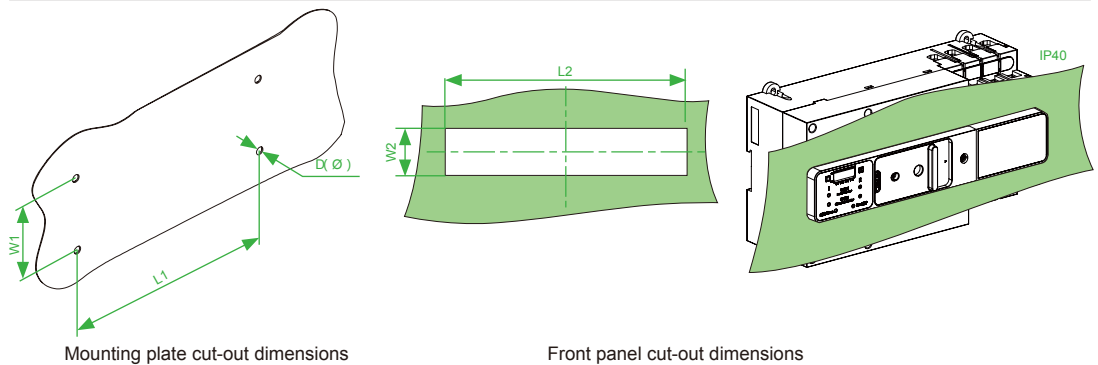

Dimension Frame	Installation dimensions			Front panel cut-out dimensions	
	L1	W1	D(∅)	L2	W2
100-2P	198	127	4.5	241	46
100-3P	198	127	4.5	241	46
100-4P	198	127	4.5	241	46
160-2P	172	136	4.5	307	46
160-3P	172	136	4.5	307	46
160-4P	172	136	4.5	307	46

Notes: (1) The launching time for the 160 frame series is subjected to further notice of the marketing department.

Dimensions and connections

Outline and installation dimensions (mm) for WATSN 250/630 frame

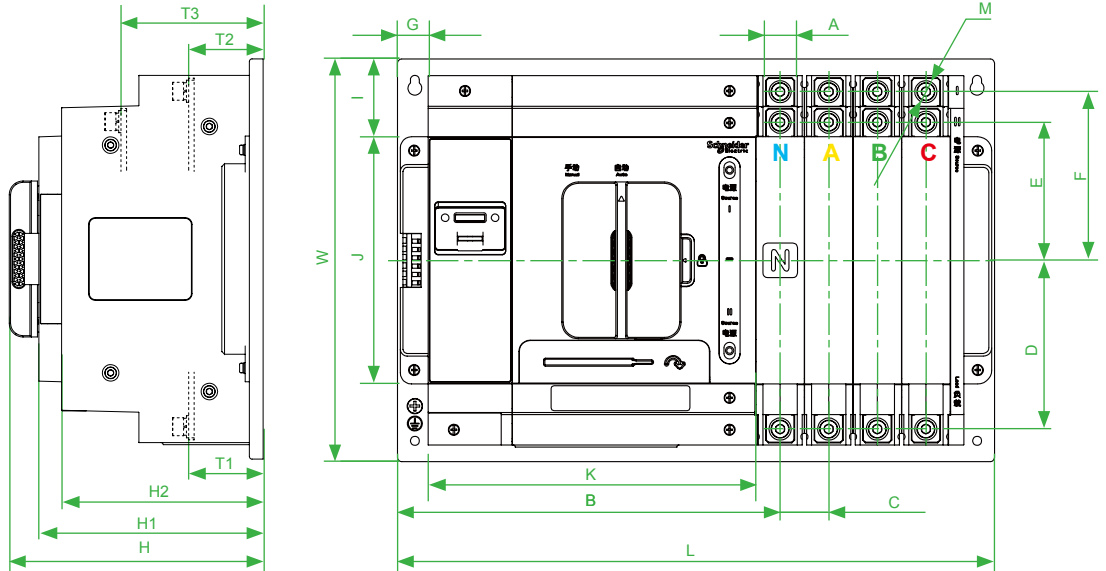

Dimension Frame	Outline dimensions					Other dimensions													
	L	W	H	H1	H2	A	B	C	D	E	F	G	I	J	K	M	T1	T2	T3
250-2P	360	290	184	162.5	146	26.8	275.6	35	121.5	99.5	121.5	22	56	178	236	M8	54	54	103
250-3P	395	290	184	162.5	146	26.8	275.6	35	121.5	99.5	121.5	22	56	178	236	M8	54	54	103
250-4P	430	290	184	162.5	146	26.8	275.6	35	121.5	99.5	121.5	22	56	178	236	M8	54	54	103
630-3P	470	356	217.5	196	174	35.6	323	45	152	118	152	23.5	80	196	277	M10	63	63	124
630-4P	515	356	217.5	196	174	35.6	323	45	152	118	152	23.5	80	196	277	M10	63	63	124

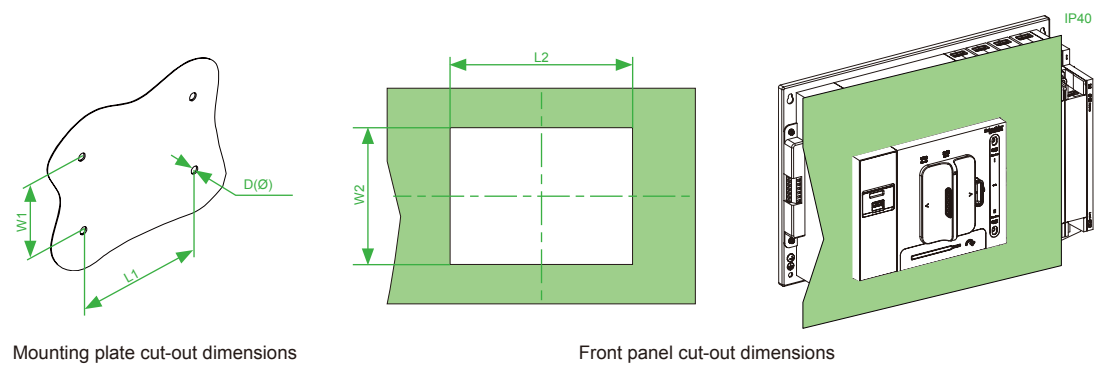

Mounting plate cut-out dimensions

Front panel cut-out dimensions

Dimension Frame	Installation dimensions			Front panel cut-out dimensions	
	L1	W1	D(Ø)	L2	W2
250-2P	335	260	6.5	237	179
250-3P	370	260	6.5	237	179
250-4P	405	260	6.5	237	179
630-3P	445	326	8.5	278	197
630-4P	490	326	8.5	278	197

Class PC transfer switch

Dimensions and connections

Outline dimensions (mm) of a WATSN add-on module

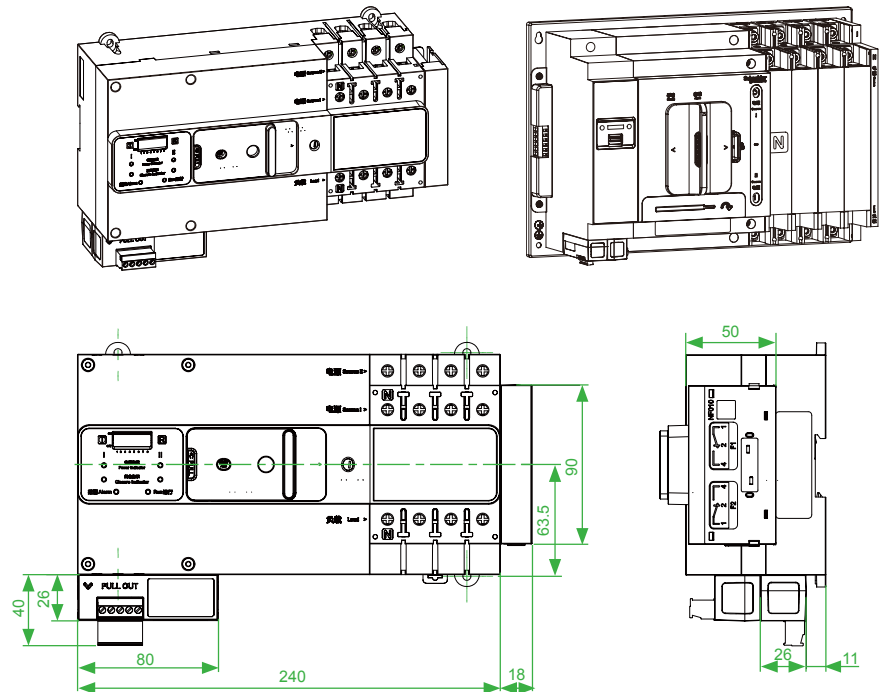

Note: The dimensions of an add-on module for the WATSN 250/630 frame are consistent with those for the module with 100/160 frame, and only the installation direction is different.

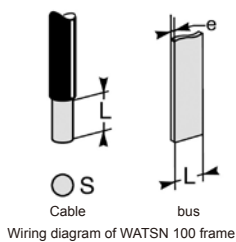

Wiring capacity

Frame		100
Pole partition	(mm)	18
bus	L(mm)	≤10
	e(mm)	≤5
Cable	L(mm)	13
	Wire Cu/Al	S(mm ²)
Rated torque	(Nm)	3.5
Torque limit	(Nm)	3.8

Note: When connecting a 1.5 ~ 4 mm² flex cable, a folded or self-folded metal ferrule is required

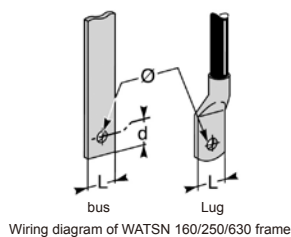

Frame		160	250	630
Pole spacing	(mm)	30	35	45
bus	d(mm)	≤10	≤10	≤19
	L(mm)	≤20	≤26	≤35
Lug	L(mm)	≤20	≤26	≤35
	Ø(mm)	≥8	≥8	≥10
Rated torque	(Nm)	8	15	50
Torque limit	(Nm)	8.5	16.5	55

Electrical wiring

Wiring diagrams of function expansion modules for the Type A controller

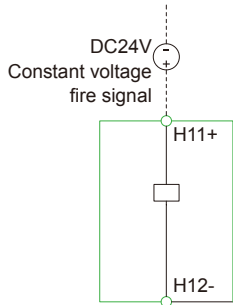

X1-DC24V constant voltage fire module

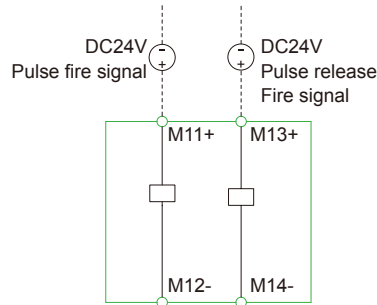

X2-DC24V pulse fire module

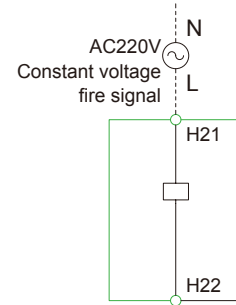

X3-AC220V constant voltage fire module

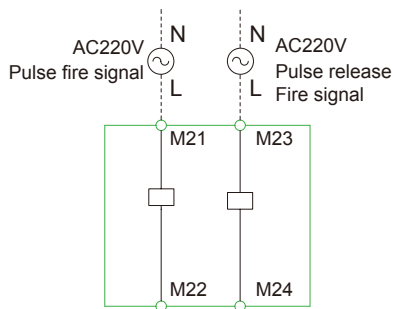

X4-AC220V pulse fire module

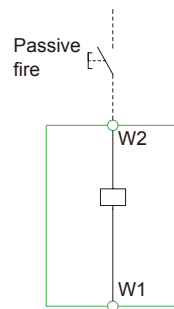

X5-Passive fire module

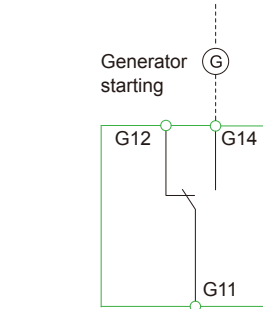

G Generator starting/cool down module

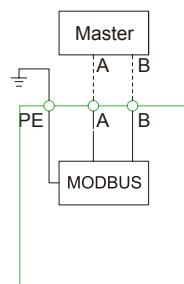

T Communication module

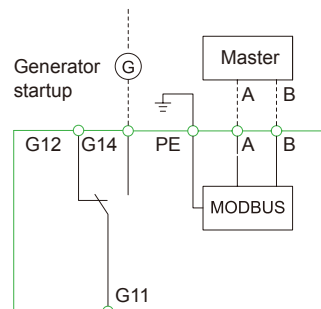

GT Generator starting/cool down + Communication module

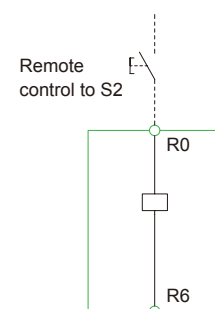

RC2 Remote transfer-to-standby module

- Notes: (1) The "fire signal" and "release signal" pins on the pulse module cannot receive the pulse signal at the same time.
 (2) The capacity of a generator start-stop terminal is DC30V 2A
 (3) The Type A controller can combine different types and functions freely. You can only select once the same function for a controller, and the number of any combined modules cannot exceed two.

Class PC transfer switch

Commercial References

Type of Product	Rated Current(A)	Number of Poles(P)	Commercial References	Short Description
Automatic Transfer Switch	63	2	NA00632V	ATS,WATSN63/2AV
Automatic Transfer Switch	63	3	NA00633V	ATS,WATSN63/3AV
Automatic Transfer Switch	63	4	NA00634V	ATS,WATSN63/4AV
Automatic Transfer Switch	160	2	N2A01602V	ATS,WATSN160/2AV
Automatic Transfer Switch	160	3	N2A01603V	ATS,WATSN160/3AV
Automatic Transfer Switch	160	4	N2A01604V	ATS,WATSN160/4AV
Automatic Transfer Switch	250	3	NA02503V	ATS,WATSN250/3AV
Automatic Transfer Switch	250	4	NA02504V	ATS,WATSN250/4AV
Automatic Transfer Switch	630	3	NA06303V	ATS,WATSN630/3AV
Automatic Transfer Switch	630	4	NA06304V	ATS,WATSN630/4AV
Remote Transfer Switch	63	2	NR00632	RTS,WATSN63/2R
Remote Transfer Switch	63	3	NR00633	RTS,WATSN63/3R
Remote Transfer Switch	63	4	NR00634	RTS,WATSN63/4R
Remote Transfer Switch	160	2	N2R01602	RTS,WATSN160/2R
Remote Transfer Switch	160	3	N2R01603	RTS,WATSN160/3R
Remote Transfer Switch	160	4	N2R01604	RTS,WATSN160/4R
Remote Transfer Switch	250	3	NR02503	RTS,WATSN250/3R
Remote Transfer Switch	250	4	NR02504	RTS,WATSN250/4R
Remote Transfer Switch	630	3	NR06303	RTS,WATSN630/3R
Remote Transfer Switch	630	4	NR06304	RTS,WATSN630/4R
Accessory			NF001	X1-DC24V Constant voltage fire linkage
Accessory			NF002	X2-DC24V Pulse fire linkage
Accessory			NF003	X3-AC220V Constant voltage fire linkage
Accessory			NF004	X4-AC220V Pulse fire linkage
Accessory			NF005	X5-Passive fire linkage
Accessory			NF006	G-Genset control module
Accessory			NF007	T-Communication module
Accessory			NF008	GT-Genset control&Communication module
Accessory			NF009	Frame 100 Terminal shield
Accessory			NF010	Frame 100 OF-contact module
Accessory			NF011	Frame 100 DIN rail latch
Accessory			NF012	RC2-Remote control to S2
Accessory			NF015	Frame 250 EIP (×3) (interphase bareer)
Accessory			NF016	Frame 630 EIP (×3) (interphase bareer)
Accessory			NF026	Frame 160 DIN rail latch
Accessory			NF027	Frame 160 Terminal shield
Accessory			NF028	T-Helper Operation and maintenance Helper



FENIGAL ELECTRIC- OPERATED BY WUXI FENIGAL SCIENCE AND TECHNOLOGY CO., LTD.